



# Building Guide

Colorado Chapter of the International Code Council

## Single Family Residential Uncovered Decks and Porches

### How to Use this Guide

Check with your jurisdiction regarding type of submittal (paper or electronic) and for additional requirements. Draw to scale and complete the following (hint: use graph paper with  $\frac{1}{4}$ " squares. Example:  $\frac{1}{4}$ " = 1')

- 1. Complete this Building Guide** by filling in the blanks on page three, and indicating which construction details will be used.
- 2. Provide Plot Plan** (site plan) showing dimensions of your project or addition and its relationship to existing buildings or structures on the property and the distance to existing property lines drawn to scale. See page 2.
- 3. Fill out a building permit application.**

The majority of permit applications are processed with little delay. The submitted documents will help determine if the project is in compliance with building safety codes, zoning ordinances and other applicable laws.

The Colorado Chapter of the International Code Council is a professional organization seeking to promote the public health, safety and welfare to building construction. We appreciate your feedback and suggestions. To obtain a master copy of this building guide, please write to the Colorado Chapter of the International Code Council, P.O. Box 961, Arvada, CO 80001.  
<http://www.coloradochaptericc.org>

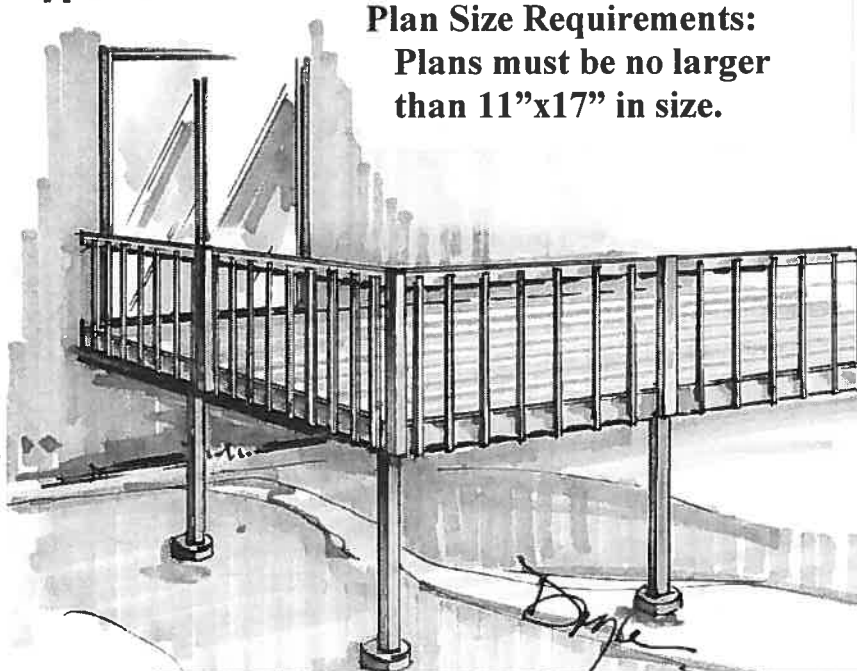

This handout was developed by the Colorado Chapter of the International Code Council as a basic plan submittal under the 2015 International Residential Code. It is not intended to cover all circumstances. Check with your Department of Building Safety for additional requirements.

City of Lafayette  
Planning & Building Dept.  
1290 S. Public Road  
Lafayette, CO 80026

# Single Family Residential Uncovered Decks and Porches

Note: A plot plan (plan view) showing the dimensions of your project or additions and its relationships to existing buildings or structures on the property must be included. In addition to project dimensions, your plan view must also show other details such as post locations and spacing, joist and beam spans, and any other pertinent information not shown on the section drawing.

## Site Plan Example

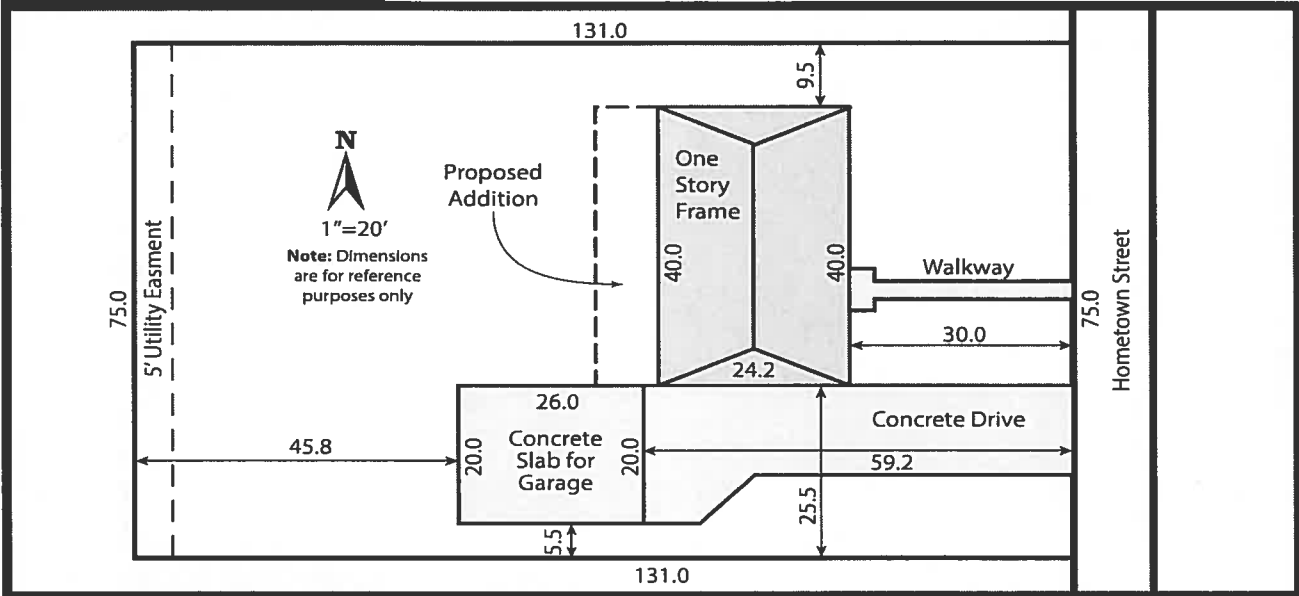

## Plan View Example

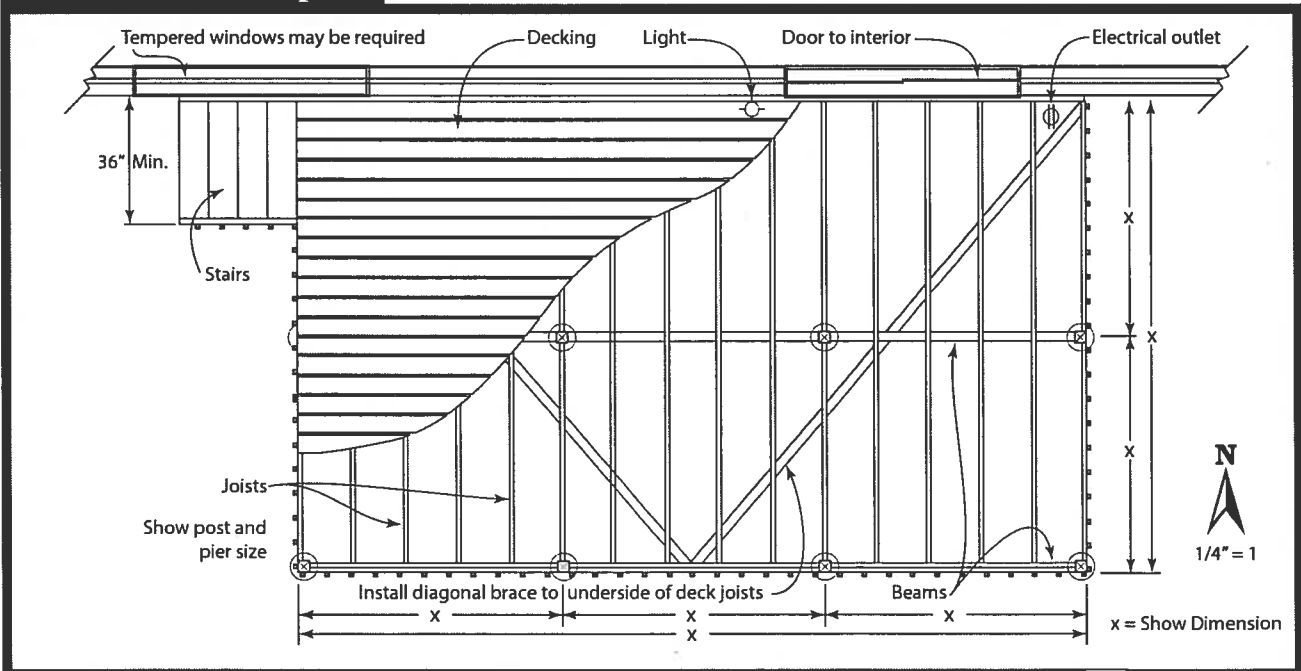

This handout was developed by the Colorado Chapter of the International Code Council as a basic plan submittal under the 2015 International Residential Code. It is not intended to cover all circumstances. Check with your Department of Building Safety for additional requirements.

**City of Lafayette**  
**Planning & Building Dept.**  
 1290 S. Public Road  
 Lafayette, CO 80026

# Single Family Residential Uncovered Decks and Porches

## Directions

1. Fill in the blanks. Please print legibly.
2. Indicate in the check box which detail from page 4 will be used.

Address: \_\_\_\_\_

### Size and Spacing of Lags

(example: Two 1/2"x 4 1/2" lags @ 16" O.C.)

Type of decking \_\_\_\_\_ x \_\_\_\_\_ - \_\_\_\_\_  
(example: 1 x 4 or 2 x 6 - Trex)

## Deck Section

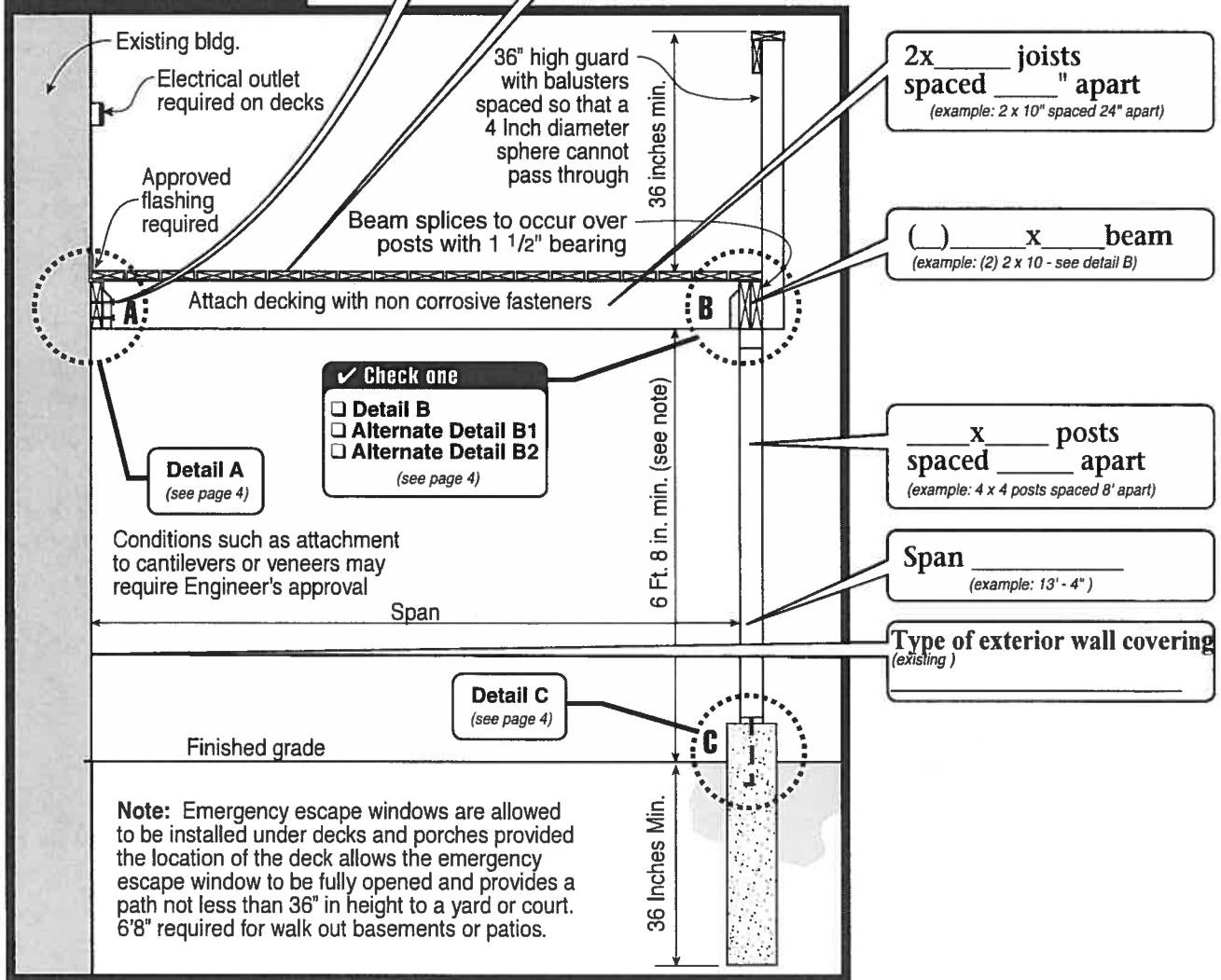

This handout was developed by the Colorado Chapter of the International Code Council as a basic plan submittal under the 2015 International Residential Code. It is not intended to cover all circumstances. Check with your Department of Building Safety for additional requirements.

City of Lafayette  
 Planning & Building Dept.  
 1290 S. Public Road  
 Lafayette, CO 80026

# Single Family Residential Uncovered Decks and Porches

## Detail A

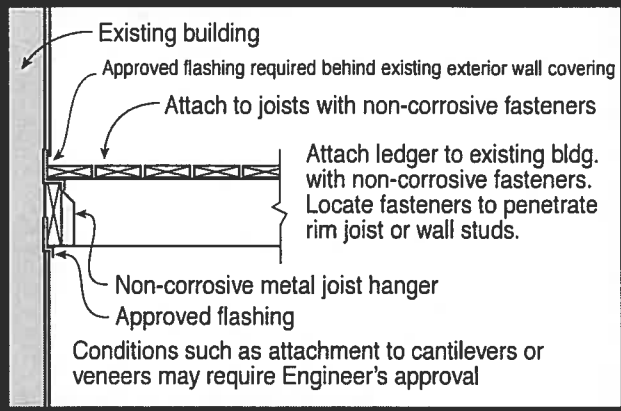

## Detail B

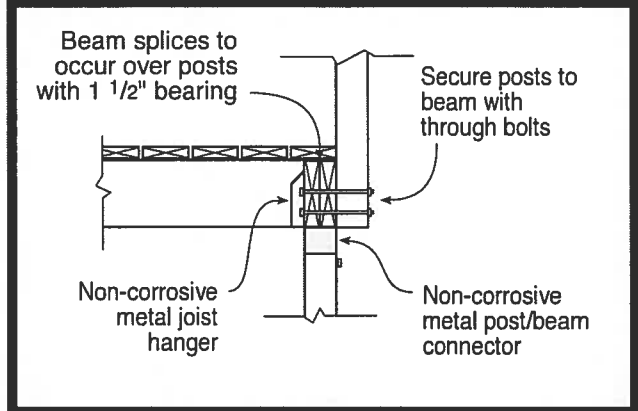

## Alternate Detail B1

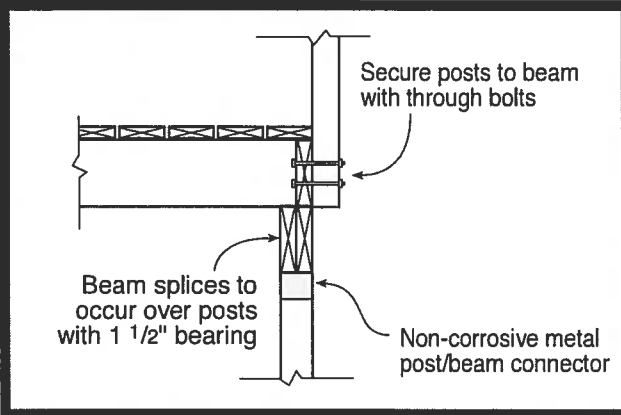

## Alternate Detail B2

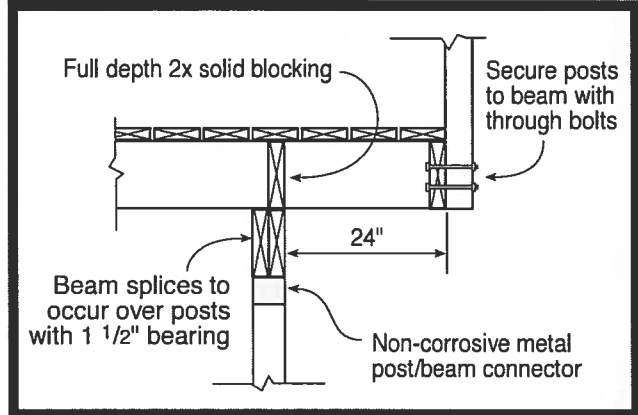

## Detail C

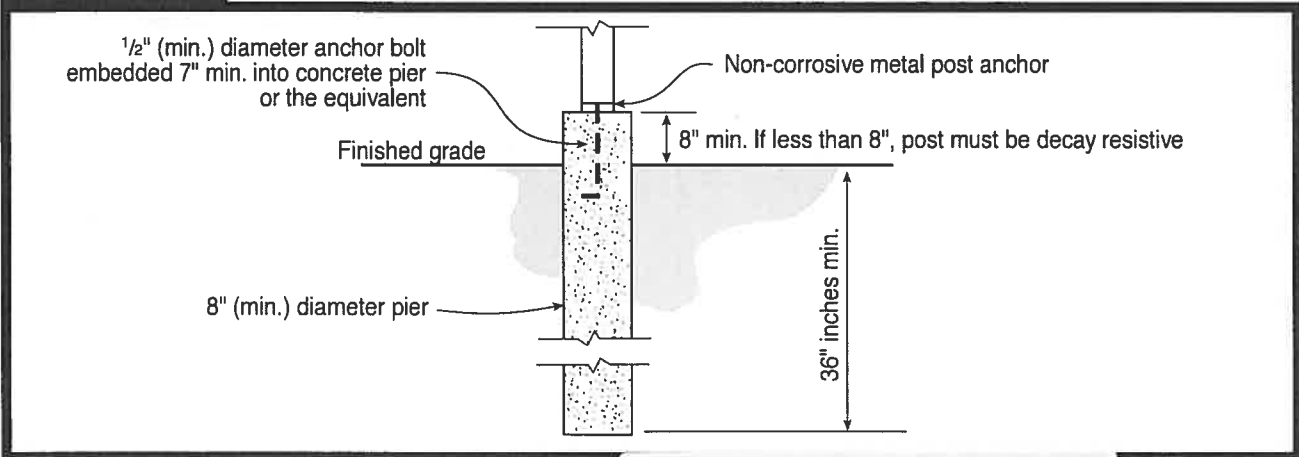

This handout was developed by the Colorado Chapter of the International Code Council as a basic plan submittal under the 2015 International Residential Code. It is not intended to cover all circumstances. Check with your Department of Building Safety for additional requirements.

**City of Lafayette**  
**Planning & Building Dept.**  
 1290 S. Public Road  
 Lafayette, CO 80026

